

SECTION 4

Metering Requirements

Customers shall provide a location for meters and associated metering equipment that is acceptable to the Utility.

Meters **shall**:

- Be in an accessible location to permit them to be read, inspected, and tested as required by the Utility. A 30" wide path to the meter must be kept clean of obstructions to a height of 6'6".
- Be located on a solid structure that is free from vibration, potential mechanical damage, and supported to maintain the meter socket in a level and plumb position.
- Be protected from damage by falling ice, snow, or other objects. A protective shield for the meter shall be provided where a roof overhang does not shield the meter.
- Have a clear working space in front of the meter panels extending out to a minimum of 36" for 208 or 240 volt services or 42" for 480 volt services. The working space shall extend vertically to a height of 6' 6" or to the height of the equipment, whichever is greater and horizontally to 24" to either side of the equipment. Where instrument transformer cabinets are used, the clear working space in front of the cabinet shall be 24" greater than the width of the cabinet cover in an open and extended position or 36" for 208 and 240 volt services or 42" for 480 volt services, whichever is greater.
- Have a minimum of 4" of clearance on all sides of the meter socket.
- Be located in a dry location free of hazardous conditions such as explosive fumes or materials.
- Be located outdoors along with all related equipment unless the Electric Department manager grants a written variance. Group-metered installations of more than 6 meters shall have a single disconnecting means. The customer shall consult the Utility before planning or installing such an installation.
- Have pedestal style meter sockets for outdoor locations for underground services. This is applicable for installations of up to 6-meter positions.
- The meter socket shall be at least 36" from any part of the gas meter or gas service.

Meters **shall not**:

- Be installed in patio, porch, deck, carport area, or areas likely to be enclosed. Changes to the customer's premise shall not result in making an existing metering location unsafe or inaccessible for reading, inspecting, or testing. The customer

will be required to make changes to this wiring if such changes create a situation that does not comply with these rules. If after a reasonable length of time has passed after receiving a non-compliance notification from the Utility and the customer has not suitably brought the installation into compliance, the Utility will terminate service until the non-compliance has been remedied.

- Be installed on mobile homes unless mobile home is installed on a permanent basement or foundation consisting of footings and frost walls.
- Have customer or customer-owned lightning arrestors or surge protection devices installed in metering equipment. The customer should install these devices on the load side of the service overcurrent protection devices. Similarly, metered and unmetered conductors shall not be installed in the same raceway or conduit, nor shall any customer meters or instruments be connected to the Utility meter wiring.
- Be installed on a driveway, sidewalk, or other high traffic areas, unless protected per figure 3-16 and MU approval.
- Bonding to other systems shall not be done on or within a metering enclosure (i.e. CATV or telephone shall not install external ground clamps on meter sockets/pedestals, ct cabinets, etc.)
- Specific equipment cannot be placed on a separate meter and metered at a different rate schedule. If a time-of-use meter is utilized, all usage must be on the time-of-use meter.
- Be enclosed or hidden from sight. This presents a safety issue when power needs to be disconnected in cases of emergency.

4.0 Multiple meter arrangements for apartment buildings and commercial shopping centers can be located indoors with advance approval from the Utility. Figure 4-1 and Table 4-1 show the requirements for these types of installations.

Table 4-1
Multiple Metering Requirements

1. A minimum clear working space of 36" for 208/240 volt or 42" for 480 volt in front of, and 24" on either side of the meter panel must be maintained. Headroom shall be a minimum of 6'6" or the height of the equipment, which ever is higher. The main entrance enclosure or termination enclosure shall be at least 4" from any barrier or wall. Also, meter sockets shall be located no closer than 10" to a barrier or wall.
2. Each meter socket must have a horn type or manual lever by-pass, be ringless, sealable, and UL approved.
3. Each meter socket must have permanent label identification, both inside and out, matching the identification of the space that is metered. This identification should be on a non-removable part of this metering equipment. Black magic marker does not meet the requirement of "permanent label identification." Marker can easily be crossed out or modified. Too often, this leads to metering mistakes and confusion. A marking with raised or indented text that will hold up through the years is required. Meters will not be set until the meter socket has been permanently labeled and the MU office has a listing of the addresses corresponding to each space metered.
4. Customer shall furnish, install and maintain multiple metering equipment. This includes all meter sockets, switches, fuses, circuit breakers, termination enclosures, load conductors, lugs, and associated equipment.
5. Meters shall be individually sealable.
6. Meters require protective barriers if traffic through a doorway could cause damage to the meter. A minimum clearance of 12" is required from the centerline of the meter-connection device to the barrier.
7. All indoor metering must be approved by the MU Electric Department Manager. If approved, a key shall be provided by the owner for 24-hour access by MU. No other materials shall be stored in the indoor metering area.
8. All single or three phase multiple meter installations may require one main disconnect for the group or individual disconnects ahead of each meter socket. Contact MU for approval before installation.

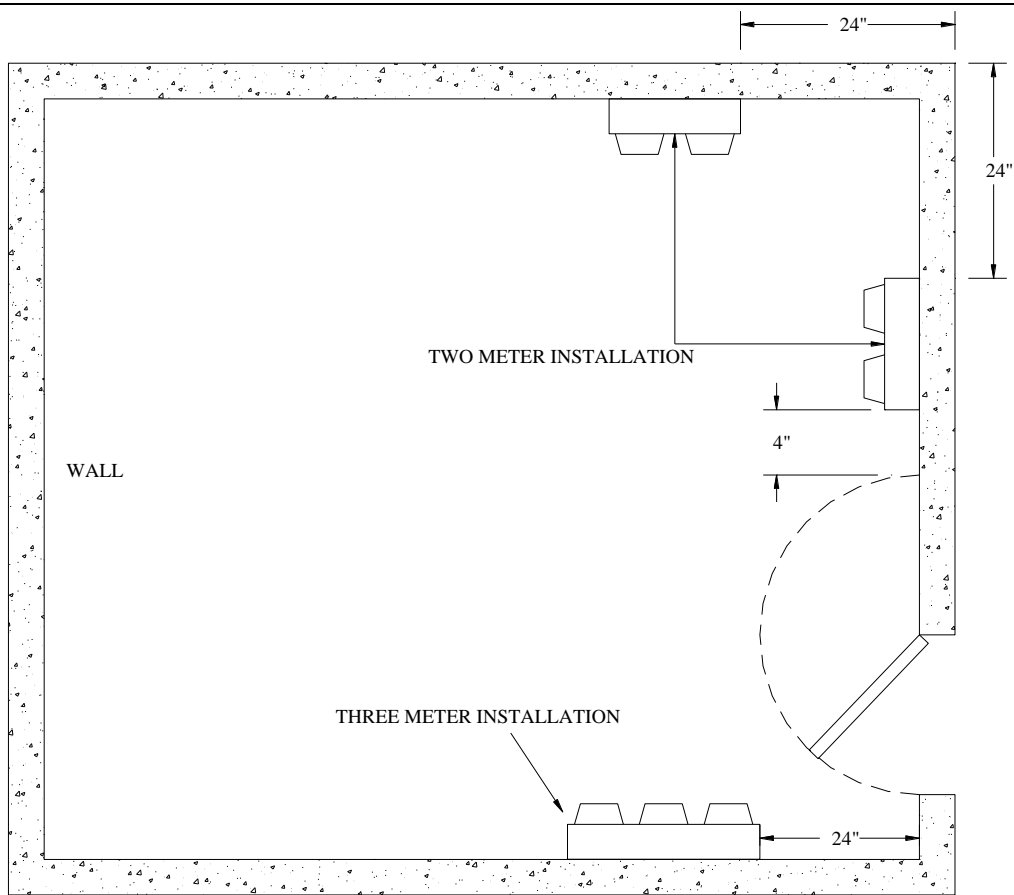

**Figure 4-1
Indoor Meter Clearance Requirements**

4.1 Meter Heights

Meters heights are located in Table 4-2. When a number of meters are placed on the same meter panel, the distance between centers should be not less than 8.5 inches vertically or 7.5 inches horizontally. For meters installed both indoors and outdoors, there shall be a minimum of 36" for 208/240 volt or 42" for 480 volt of unobstructed space in front of the meter measured from the surface of the meter enclosure.

Table 4-2 Meter Height Clearance Requirements		
	PSC 113 required Range	MU preferred Range
Outdoor Overhead meter	4' – 6'	4' - 5' 6"
Outdoor Underground meter	2' 6" – 6'	2' 6" - 5' 6"
Indoor meter	4' – 6'	4' - 5' 6"
Outdoor meter pack	2' 6" – 6'	2' 6" – 5' 6"
Indoor meter pack	2' 6" – 6'	2' 6" - 5' 6"

All measurements are from final ground grade to the center of the meter glass.

4.2 Meter Sockets

- Single Phase

- Must be UL approved, be rated 200 amperes minimum, be ringless, sealable, and have manual bypass horns.
- Table 4-4 through 4-14-list pre-approved single-phase meter sockets.
- Other meter sockets/pedestals to what is listed in the tables may be used with prior MU approval.

Table 4-3	
Example 200 Amp Overhead Meter Sockets without Main Breaker	
Manufacturer	Catalog #
Milbank	U1773-XL-TG-KK

Table 4-4	
Approved 200 Amp Overhead Meter Sockets with Main Breaker	
Manufacturer	Catalog #
Midwest	R281CB1
Milbank	U5844-PXL-200

Table 4-5		
Approved 200 Amp Service Pedestals without Main Breaker		
Manufacturer	Catalog #	Pedestal Extension if needed
Landis & Gyr (Siemens)	UAP317-PPWI	5007718 (15")
		5007725 (30")
Milbank	U3358-0-KK	K5800 (15")
		(2) - K5800 (30")
Eaton (Cutler Hammer)	UHTRP242363CH	1007680CH (18")
		1008786CH (30")
Square D	UHTRP242363	1009618 (18")
		1008786 (30")

Table 4-6		
Approved 200 Amp Service Pedestals with Main Breaker		
Manufacturer	Catalog #	Catalog # for Breaker

Landis and Gyr	UAPB317-PPWI H659-0121 5007718 5007725	200-amp single-phase pedestal 5 th terminal grounded – kit if needed. 15” Pedestal extension 30” Pedestal extension
Milbank	NU8980-O-KK-LP UQFP-M-200 UQFPH-M-200 K4714 5T8K2 K4694	200 A single phase ped low profile 200 amp breaker (10,000 AIC) 200 amp breaker (22,000 AIC) Series wiring kit 5 th terminal kit if needed 24” Pedestal extension
Milbank (Unit has provisions for two receptacles)	U5706-O-200S-KK K5T K5708	200-amp single-phase pedestal 5 th terminal kit if needed 12” Pedestal extension

**Table 4-7
Approved Mobile Home Pedestals**

Manufacturer	100 Amp Single Position	200 Amp Single Position	100 Amp Duplex	200 Amp Duplex
Midwest	R101CP6HP EK129	R281C1P6H EK129	R101CB6HP EK129	R281C1B6H EK129
Milbank	U5136-O-100S	U5136-O-200S	U5137-O-100S	U5137-O-200S

**Table 4-8
Approved Multi-Meter Socket Arrangements without Main Breaker 200 Amp Rated**

Manufacturer	Service	# Of positions	Catalog #	Pedestal Extension	5 th Terminal
Milbank	OH	2	U1252-X-KK	----	K5T
Milbank	OH	3	U1253-X-KK	----	K5T
Milbank	OH	4	U1254-X-KK	----	K5T
Milbank	UG	2	U1252-X-KK-K1-PED*	S2571 (12”)	K5T
Milbank	UG	2	U1783-O-KK	S8988 (30”)	K5T
Milbank	UG	3	U1253-X-KK-K3-PED*	S2571 (12”)	K5T
Milbank	UG	4	U1254-X-KK-K3-PED*	S2571 (12”)	K5T
Milbank	UG	5	U1255-X-KK-K4-PED*	S2571 (12”)	K5T
Milbank	UG	6	U1256-X-KK-PED*	S2571 (12”)	K5T

* Must order catalog number S2291-TO for pedestal raceway, also.

Table 4-9						
Approved Multi-Meter Socket Arrangements with Main Breaker 200 Amp Rated						
Main Bus Rating	Manufacturer	Service	# Of positions	Catalog #	Pedestal Extension	5 th Terminal
250 A	Milbank	UG	2	U2862-X-KK-K1-PED* **	S2571	K2381
300 A	Milbank	UG	3	U2863-X-KK-K1-PED* **	S2571	K2381
400 A	Milbank	UG	4	U2864-X-KK-PED* **	S2571	K2381
600 A	Milbank	UG	5	U2865-X-KK-PED* **	S2571	K2381
600 A	Milbank	UG	6	U2866-X-KK-PED* **	S2571	K2381

* Must order catalog number S2291-TO for pedestal raceway, also.

** Units are not supplied with circuit breakers; order as extra.

Please contact the Utility to discuss the arrangement for installations involving more than one meter at a single location.

Table 4-10		
Approved 320/400 Amp Service Pedestals Without Main Breaker		
Manufacturer	Catalog #	Pedestal Extension Catalog #
Landis & Gyr	47604P-9WI	5007719 (15")
Milbank*	U1748-O-WI-K1350 K4802 (2 – 350 kcmil)	S1848 (15")

* Order (1) Anti-Inversion Clip, K4802

Table 4-11		
Approved 320/400 Amp Service Pedestals With Main Breaker		
Manufacturer	Catalog #	Pedestal Extension Catalog #
Milbank*	U3849-O-2/200 K1350 K4802 (2 – 350 kcmil)	S1848 (15")

* Order (1) Anti-Inversion Clip, K4802

Table 4-12	
Approved 320/400 Amp Overhead Meter Sockets Without Main Breaker	
Manufacturer	Catalog #
Milbank*	U1779-RRL-K3-K1350 K4802 (2 – 350 kcmil)

* Order (1) Anti-Inversion Clip, K4802

Table 4-13	
Approved 320/400 Amp Overhead Meter Sockets With Main Breaker	
Manufacturer	Catalog #
Milbank*	U5890-X-2/200-BL K4802

* Order (1) Anti-Inversion Clip, K4802

Table 4-14	
Approved Single Phase Instrument Rated Meter Socket for 400 and 600 Amp Services with Test Switch and Pre-Wired (For use in conjunction with a CT cabinet)	
Manufacturer	Catalog #
Durham	ASTS6-1CTBA SKT/SW 20A 6T FW HCP*

*Includes test switches. MU stocks these sockets for purchase.

Three phase

- Must be rated at 600 volts, 200 amperes minimum, be UL approved, ringless, and have clamp type jaws.
- Shall have a lever bypass which is designed to permit visual checking of the bypass connections with the meter installed. The socket must also be designed so that the cover cannot be installed in the bypass-closed position.
- Table 4-15 lists pre-approved meter sockets and Figure 4-2 shows the typical electrical connections for 200 ampere three phase, four wire applications.
- A disconnect may be required before the meter socket. Contact MU for approval before installation.

Table 4-15		
Approved Meter Sockets for Self-Contained 200 Amp Three Phase Four Wire Services		
Manufacturer	OH Catalog #	UG Catalog # / Extension #
Landis & GYR	40007-01QG	40407P-9WI / 5007720
Milbank	U9700-RRL	U9107-O-WI / S3488

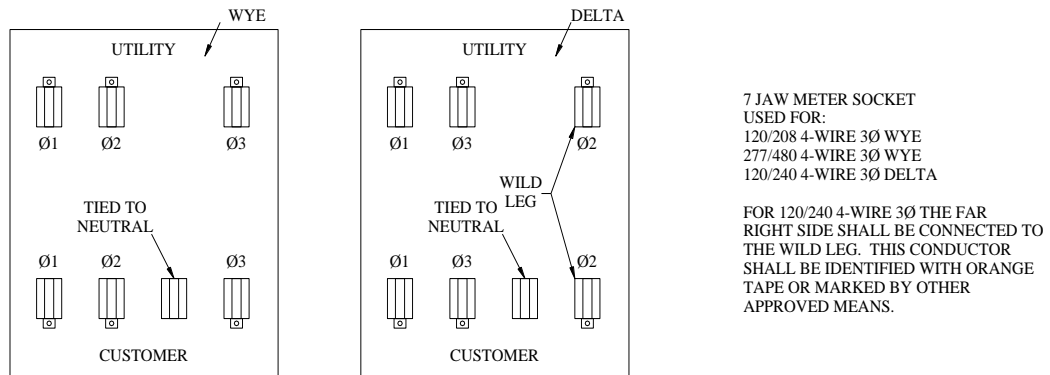

Figure 4-2
Three Phase Four Wire Meter Socket Connections

Table 4-16 Approved Three Phase Transformer Rated Meter Sockets with Test Switch and Pre-Wired	
Manufacturer	13 terminal, 120/208 and 277/480
Durham	1008348 (includes test switch)*

* MU stocks these sockets for purchase.

4.3 Instrument Transformer Metering - General

This metering requirement is applicable for services from 400 amperes through 2000 amperes. For 400-ampere single-phase services, a 320-ampere plug-in meter socket is standard for residential and some commercial services. MU should be consulted before using CT cabinets. Other general requirements are noted below in the narrative, associated diagrams, and tables.

1. The customer shall install the meter socket, current transformer cabinet, and conduit between the meter socket and CT cabinet. The Utility will supply the meter, current transformers, and meter wiring.
2. The CT cabinet and meter socket must be mounted outdoors.
3. The minimum clear space in front of the CT cabinet shall be 36" for 208/240 volt or 42" for 480 volt or 2' beyond the maximum cover swing distance, whichever is greater.
4. In four-wire 120/240-volt three-phase installations, the wild leg shall be located on the right side and identified with orange tape.
5. The CT cabinet must be bonded in accordance with NEC 250.102(d).
6. MU will bond the meter socket.
7. Pre-approved meter socket are shown in Table 4-16.
8. A rain tight hub or gasket must be used on all conduit connections to the CT cabinet and the meter socket.
9. All CT/PT cabinets must have provisions for installation of a padlock and meter seal by MU.

10. The CT cabinet must be weather tight (NEMA 12), and must be large enough to allow ample space for CT's, PT's, and conductors.

Current Transformers

Current transformers are to be installed in an approved cabinet or in the pad-mounted transformer with Utility permission. All low side wiring on the current transformers will be done by MU. Polarity marks (H1 or white dot) on the CT window must face in the direction of the supply. Conductors are to be routed from the transformer and enter the CT at the end with the polarity mark. All conductors of each phase must pass through the same current transformer. The Utility will furnish all current transformers.

Potential Transformers

Potential transformers will be required on all transformers rated 480-volt services. Potential transformers may be mounted in the same cabinet as the current transformers or, with MU approval, internal to the padmounted transformer. The potential transformers should be mounted in a location where the conductors will not interfere with proper access. All wiring on the potential transformers will be done by MU. The Utility will furnish all potential transformers.

4.4 Current Transformers in Padmounted Transformers

This metering option is only available with the permission of MU. In addition, the transformer can only be used to supply a single service to one building and the customer shall own, install, and maintain the service conductors.

The customer shall provide the meter socket. It can be installed near or on (with MU approval) the padmount transformer, or installed on the building wall. If it is installed on the building wall, the maximum distance shall be 15' from the padmount transformer to the building wall.

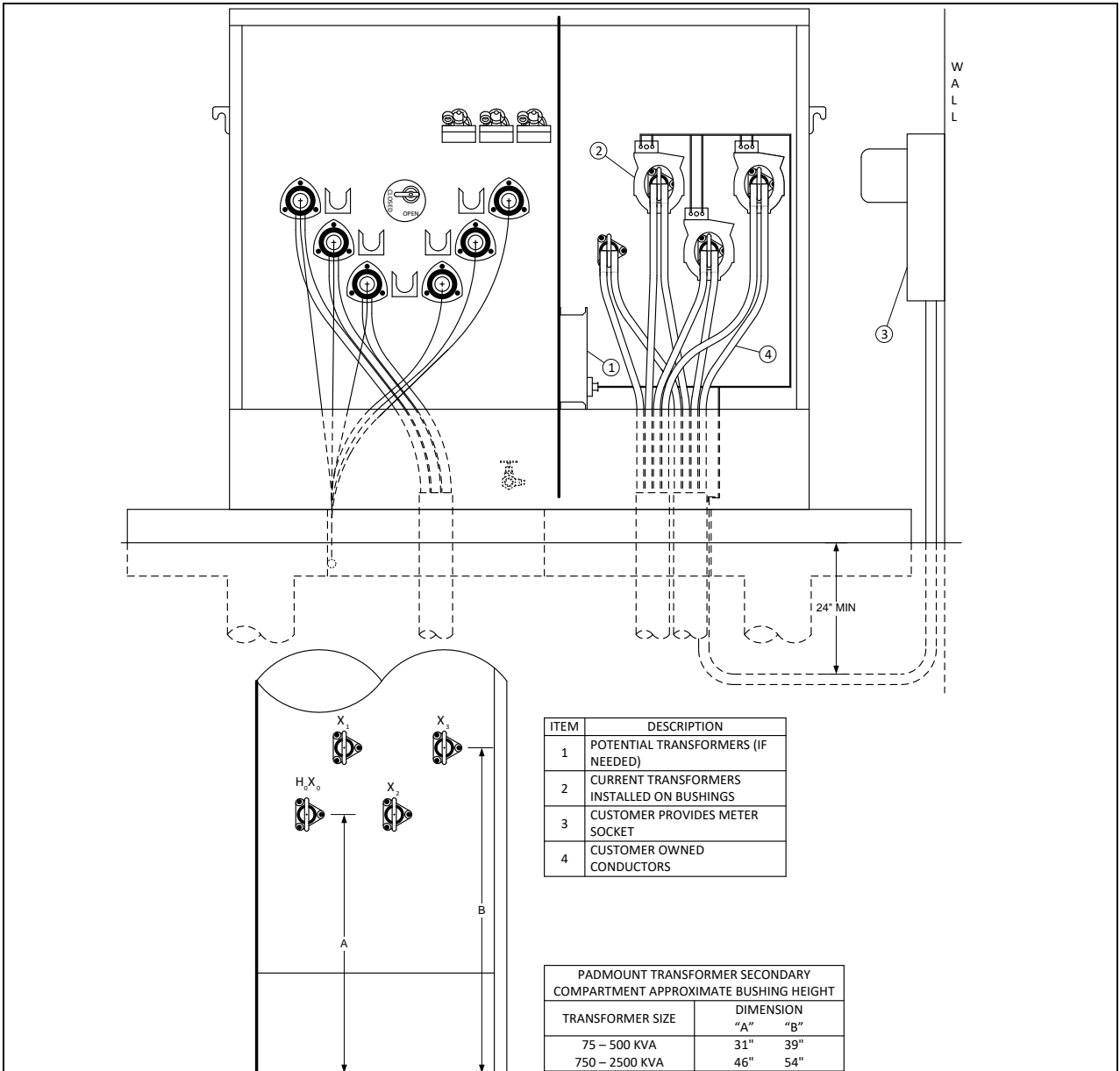
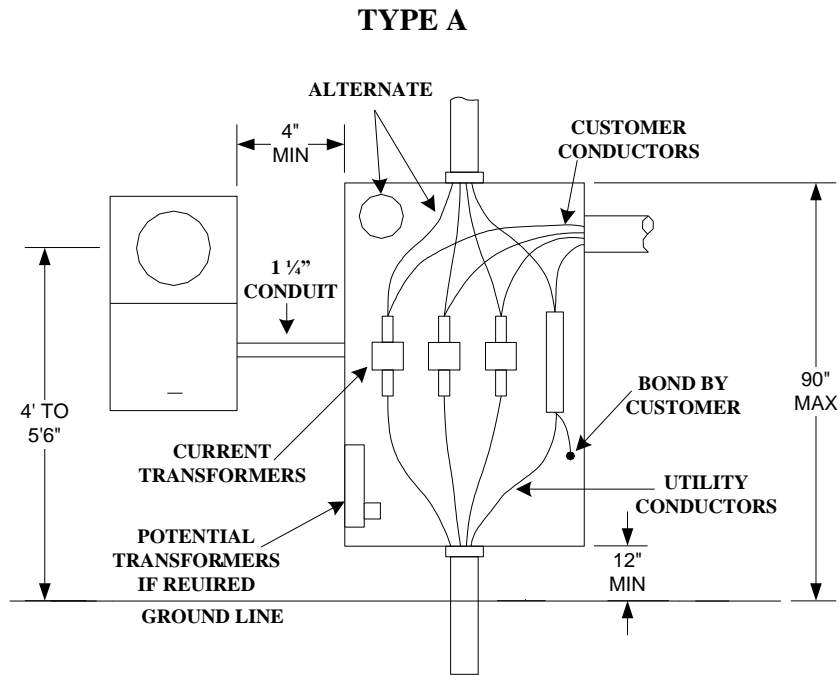

**Figure 4-3
Three Phase Transformer Metering Arrangement**

Termination enclosures may be necessary with certain wiring, spacing, clearance, or equipment choices. The customer should consult with the Utility before planning or utilizing these enclosures.

4.5 Current Transformer Cabinets for 400-2000 Ampere Services

This metering arrangement is applicable for services rated 400-2000 amperes using bolt-in current transformers only. For 400-ampere single-phase services, a 320-ampere plug-in meter socket is standard for residential and certain commercial services. MU should be consulted before using CT cabinets.



*CUSTOMER TO PROVIDE CT CABINET AND METER SOCKET (MU WILL BOND METER SOCKET)
 *RAIN TIGHT HUB(S) OR GASKET(S) SHALL BE USED ON ALL CONDUIT(S)

Figure 4-4 (a)
Three Phase Current Transformer Cabinet Arrangements

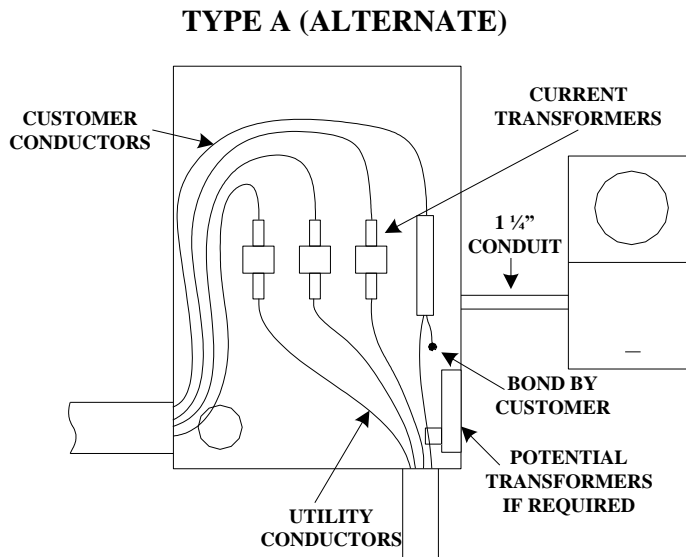

*SEE TYPE A FOR DIMENSIONS AND NOTES

Figure 4-4 (b)
Three Phase Current Transformer Cabinet Arrangements

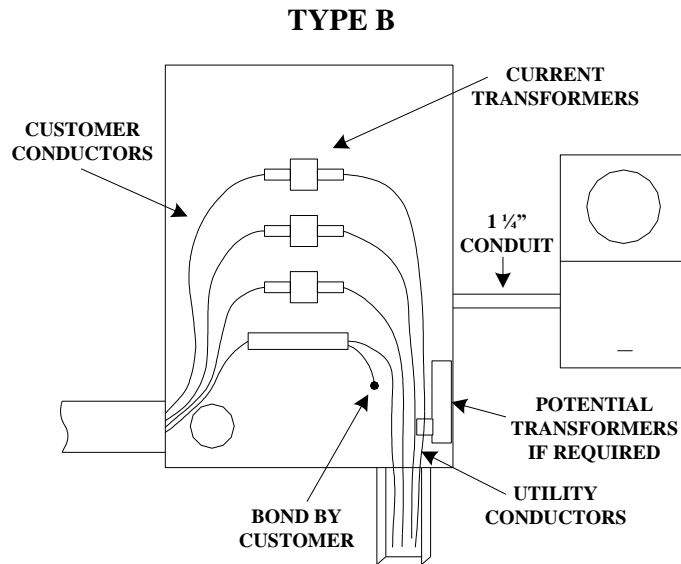

*SEE TYPE A FOR DIMENSIONS AND NOTES

Figure 4-4 (c)
Three Phase Current Transformer Cabinet Arrangements

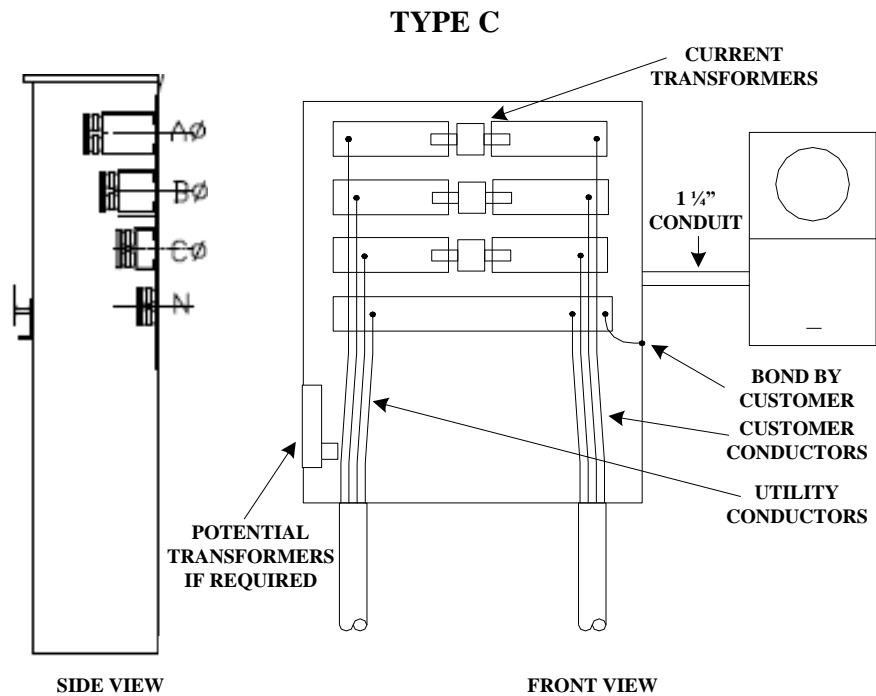

*SEE TYPE A FOR DIMENSIONS AND NOTES

Figure 4-4 (d)
Three Phase Current Transformer Cabinet Arrangements

TABLE 4-17 CURRENT / POTENTIAL TRANSFORMER CABINETS

SIZE	# OF WIRES	MFG	CATALOG #	HxWxD	FAULT CURRENT	TYPE (FIG 4-4)	277/480 VOLT (ROOM FOR PT PACK?)
400A	3	Erickson	1182-1 WPS	45.5x20x7.25	42,000	A	NO
400A	3	Galva Closure	WPS-403UG	42x20x8	65,000	A	NO
400A	3	EMI	CTB146-WPS	48x30x10	65,000	A	YES
400A	3	AMP	WPSCT4-3TM	48x36x15	85,000	A	YES
400A	3	AMP	WPSSB8-3ACT	60x36x15	50,000	C	NO
400A	4	Erickson	1182-2 WPS	45.5x20x7.25	42,000	A	NO
400A	4	Galva Closure	WPS-404UG	42x20x8	65,000	A	NO
400A	4	EMI	CTB346-WPS	48x30x10	65,000	A	YES
400A	4	AMP	WPSCT4-4TM	48x36x15	85,000	A	YES
400A	4	AMP	WPSSB8-4ACT	60x36x15	50,000	C	NO
600A	3	Erickson	1076-1 WPS-LE	60x36x15	65,000	A	YES
600A	3	Galva Closure	WPS-603UG	54x36x14	65,000	A	YES
600A	3	Galva Closure	WPS-603UGA	48x46x12	65,000	B	YES
600A	3	EMI	CTB146-WPS	48x30x10	65,000	A	YES
600A	3	AMP	WPSCT68-3TM	48x36x15	85,000	A	YES
600A	3	AMP	WPSSB8-3ACT	60x36x15	50,000	C	NO
600A	4	Erickson	1076-2 WPS-LE	60x36x15	65,000	A	YES
600A	4	Galva Closure	WPS-604UG	54x36x14	65,000	A	YES
600A	4	Galva Closure	WPS-604UGA	48x46x12	65,000	B	YES
600A	4	EMI	CTB346-WPS	48x30x10	65,000	A	YES
600A	4	AMP	WPSCT68-4TM	48x36x15	85,000	A	YES
600A	4	AMP	WPSSB8-4ACT	60x36x15	50,000	C	NO
800A	4	Erickson	1076-2 WPS-LE	60x36x15	65,000	A	YES
800A	4	Galva Closure	WPS-804UG	54x36x14	65,000	A	YES
800A	4	Galva Closure	WPS-804UGA	48x46x12	65,000	B	YES
800A	4	EMI	CTB380-WPS	48x30x10	65,000	A	YES
800A	4	AMP	WPSCT68-4TM	48x36x15	85,000	A	YES
800A	4	AMP	WPSSB8-4ACT	60x36x15	50,000	C	NO
1200A	4	Erickson	CUCT-124WPS	60x51x15	85,000	B	YES
1200A	4	Galva Closure	WPS-1204UG	48x46x12	65,000	B	YES
1200A	4	AMP	WPSCT12-4TM	48x36x15	85,000	A	YES
1600A	4	Erickson	UCT-164WPS	60x60x15	85,000	B	YES

1600A	4	Galva Closure	WPS-1604UG	60x60x14	65,000	B	YES
1600A	4	AMP	WPSCT16-4TM	60x36x15	85000	B	NO
2000A	4	Erickson	CT204SG-WPS	60x66x15	100,000	B	YES
2000A	4	Galva Closure	WPS-2004-UG	60x60x14	65,000	B	YES
2000A	4	EMI	CTB320WPS	72x46x18	65,000 or 85,000	A	NO

4.6 Metering in Switchgear 1600 through 3000 Amperes

This metering option is available to customers with a 1600 through 3000-ampere service entrance. The customer should consult with MU early in the planning and design phase on metering and current transformer layouts to obtain timely approvals. There are two fundamental alternative designs, which are depicted in Figures 4-5 and 4-6.

Elements common to the design of both alternatives are:

1. The minimum depth of the current transformer cabinet is 24"
2. Doors shall be hinged and have a lockable hasp.
3. Buses should be braced to support conductors and CT's.
4. CT's must be adjustable for depth and height.
5. Bus shall be adequately braced to support CT's and conductors.
6. The customer should submit detailed drawings to MU for approval before ordering any equipment.

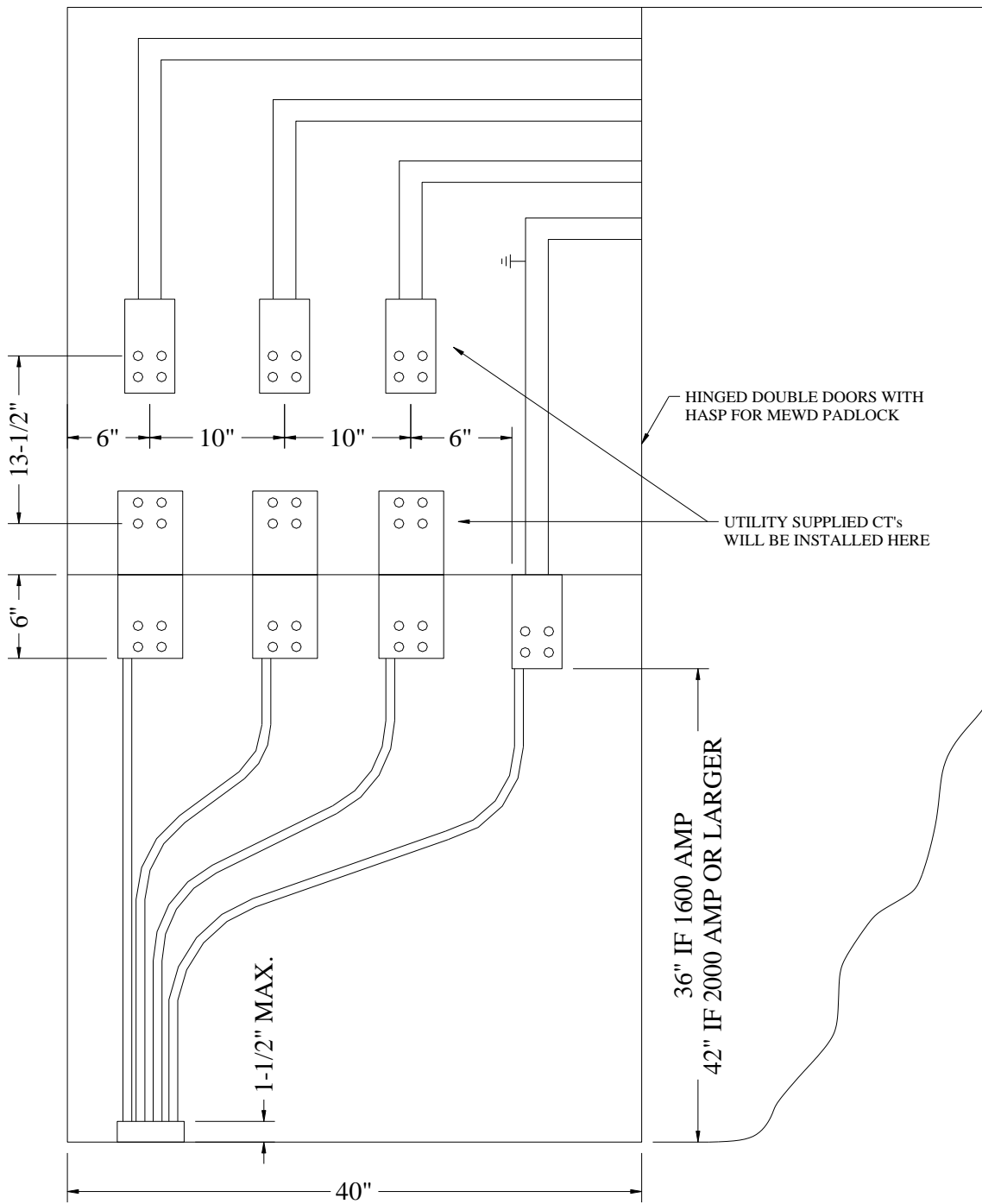

Figure 4-5
Three Phase Metering in Switchgear with Bar-type Current Transformers

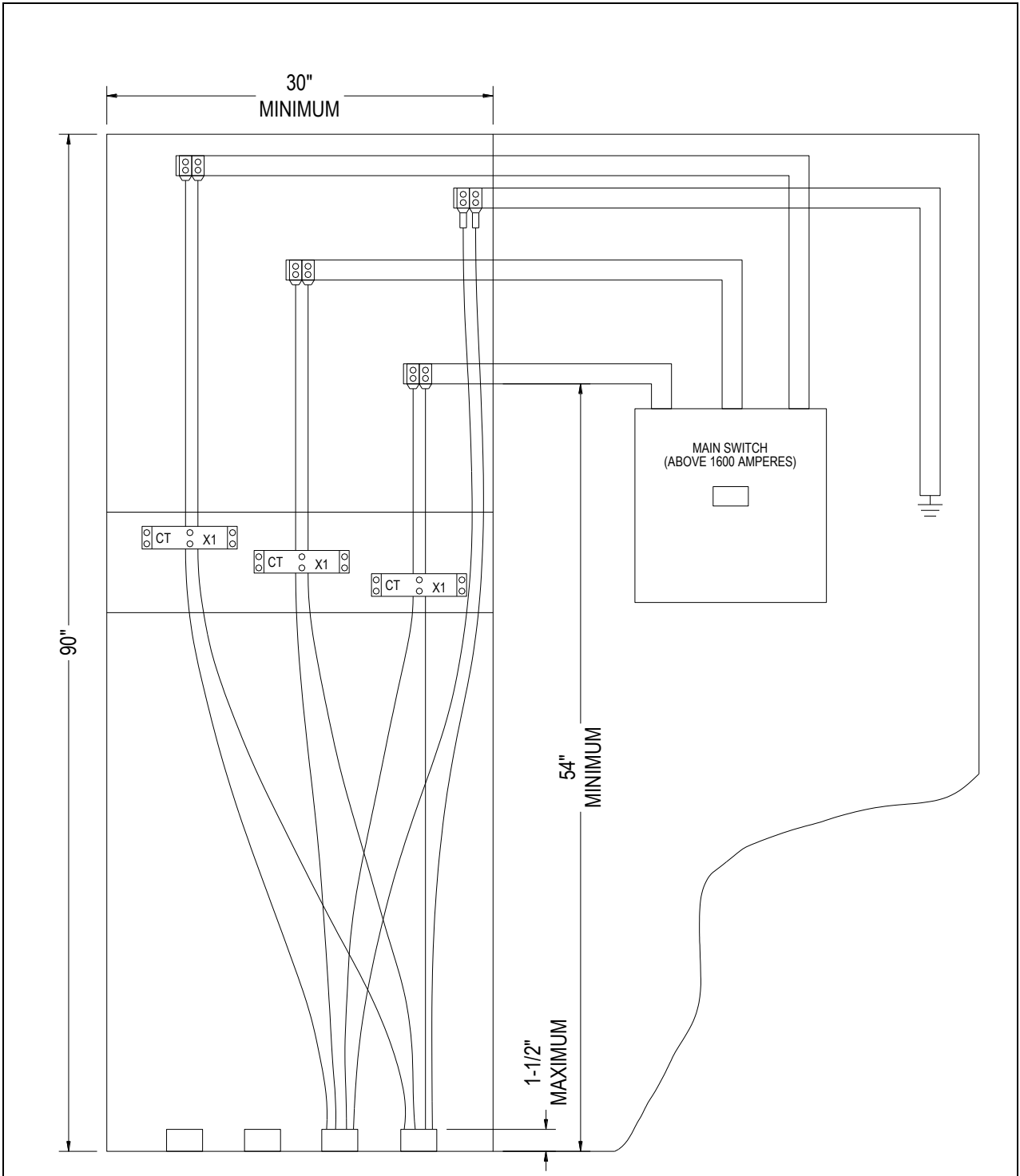

Figure 4-6
Three Phase Metering in Switchgear with Window-type Current Transformers

4.7 Primary Metering

Three-phase 13.2 kV primary voltage service is only available upon request by the customer and approval by MU. The customer must make application to the Utility for the proposed primary service and obtain approval of the location, equipment, and design before starting installation of the service entrance.

The Utility furnishes, installs, and maintains the primary service and metering equipment in accordance with the Utility's applicable rates and extension rules. The customer furnishes, installs, and maintains all service entrance facilities at the service point other than the metering equipment regardless of the metering location.

General requirements for primary metered service include:

1. The customer shall submit the plans for the location, equipment, and design to MU for approval.
2. The customer's system beyond the metering point must comply with the NEC and the Wisconsin Electrical Code Volume II requirements. Some of the key requirements are:
 - a. Overcurrent protection of branch lines and transformer overcurrent protection on the primary side of all transformers must be provided.
 - b. Overcurrent protection on the secondary side of transformers.
 - c. Clearances and separations must be maintained to the utilities metering equipment. See Section on Clearances.
3. The customer should avoid utilizing three-legged core transformers. Only grounded wye/grounded wye five-legged or triplex core transformers should be used. This is to minimize the possibility of ferro-resonance with loss of a phase. Contact MU for approval to use delta-wye wound transformers.

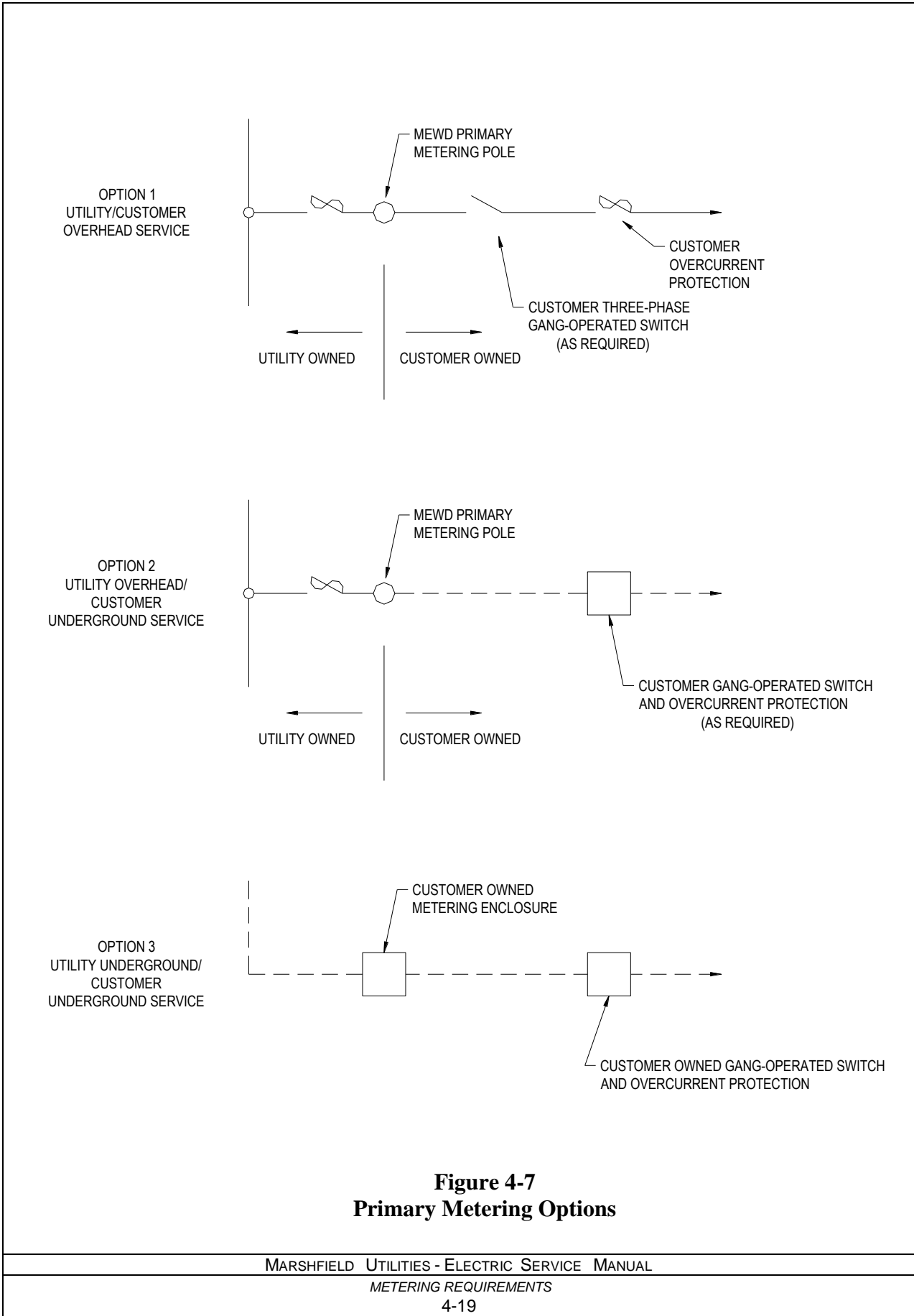

**Figure 4-7
Primary Metering Options**

4.8 Meter Ice and Snow Shield

Where meters are not protected by a building overhang and are subject to damage from falling ice and snow, particularly from metal roofs, the following meter ice and snow shield shown in Figure 4-8 shall be utilized. The customer is responsible for furnishing and installing the shield, and for repair costs resulting from damage caused by ice or snow. Unpainted stainless steel or steel shields that are primed and painted with rust-resistant paint are allowed. Shields shall be a minimum of 10 gauge. Wood or Plywood shields are not allowed.

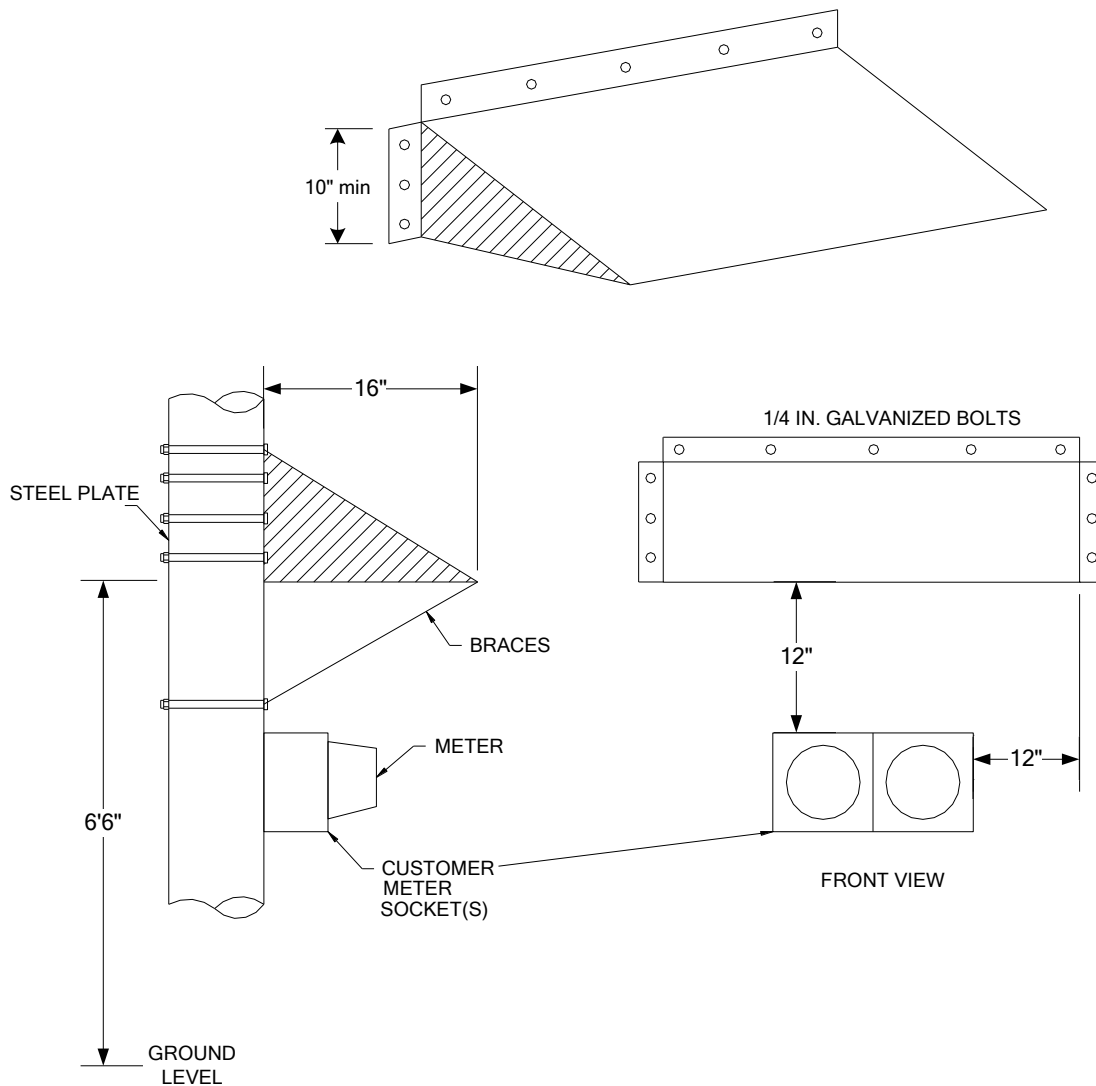

Figure 4-8
Meter Ice and Snow Shield